

### 技术说明

1. 臂展: 1333mm;
2. 负载: 10KG;
3. 自重: 37KG;
4. 抱闸类型: 24/12VDC电磁摩擦式;
5. 中间过线通孔最大尺寸:  $\varnothing 12$ mm ;

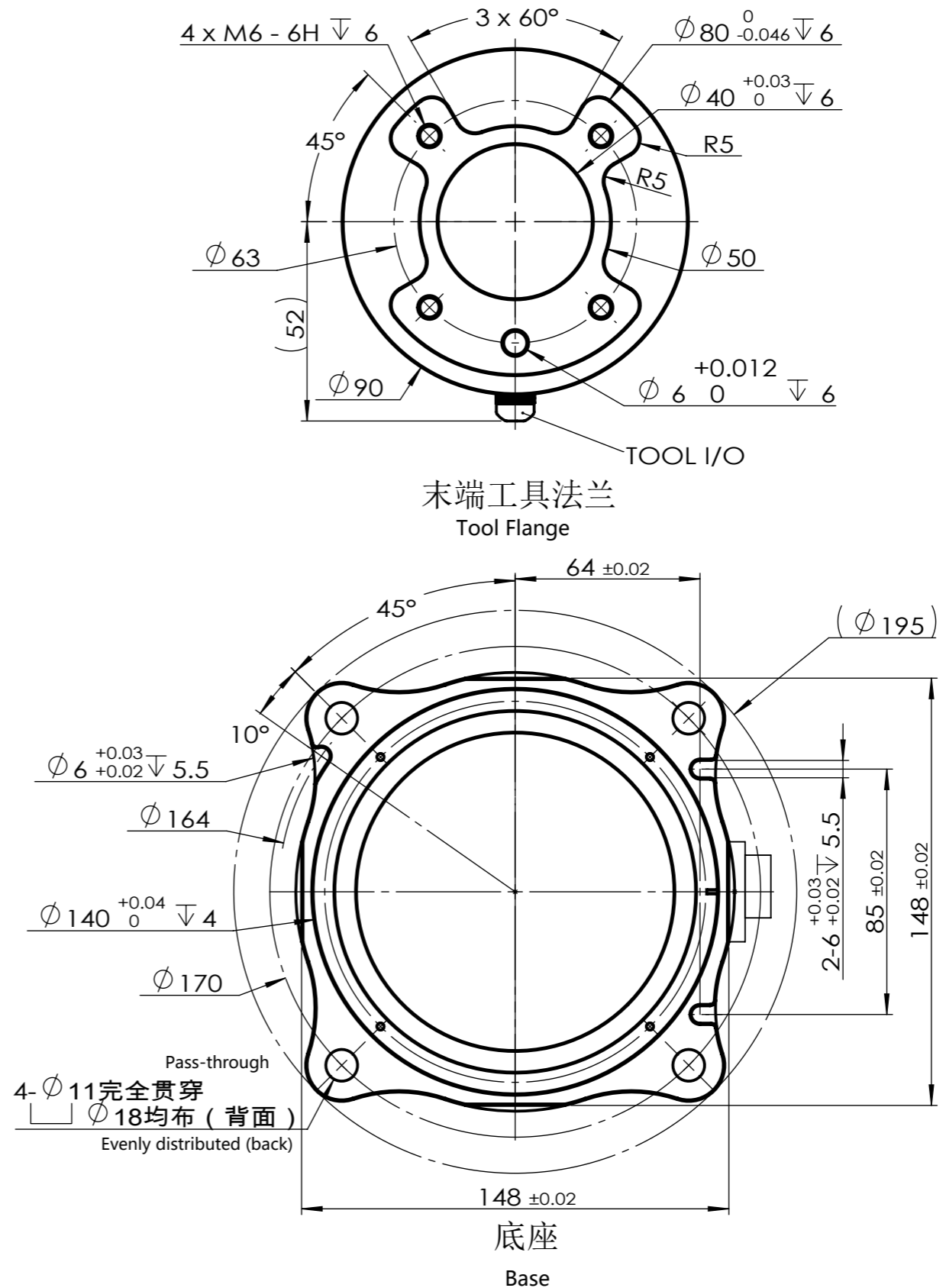

### Technical Description

1. Arm span: 1333mm.
2. Rated load: 10KG.
3. Weight: 37KG.
4. Brake type: 24/12VDC electromagnetic friction type.
5. Maximum size of the through-hole in the middle:  $\varnothing 12$ mm.