

机械参数 Mechanical Parameters	单位 Units	数值 Values
减速器速比 Reducer Ratio	—	101
减速器背隙 Reducer Backlash	arcsec	10
转动精度 Rotational Accuracy	arcmin	1
平均负载转矩 Average Load Torque	N·m	133
启停容许转矩 Start/Stop Allowable Torque	N·m	194
最大瞬时转矩 Maximum Instantaneous Torque	N·m	351
最大许用弯矩 Maximum Permissible Bending Moment	N·m	243
最大瞬时弯矩 Maximum Momentary Bending Moment	N·m	480
额定转速 Rated Speed	rpm	24.8
最大转速 Maximum Speed	rpm	31.4
关节重量 Joint Weight	kg	3.4
关节直径 Joint Diameter	mm	110
关节长度 Joint Length	mm	126

电气参数 Motor Parameters	单位 Units	数值 Values
极对数 Number of Poles	—	6
额定功率 Rated Power	W	400
额定电压 Rated Voltage	VDC	48
额定电流 Rated Current	Arms	11.5
额定转速 Rated Speed	rpm	3000
额定转矩 Rated Torque	N·m	1.4
转矩常数 Torque constant	N·m/A	0.15
线反电动势 Back Electromotive Force Coefficient	Vrms/krpm	9.8
制动 Brake	—	24/12VDC电磁摩擦式 24/12VDC electromagnetic friction type
输出反馈 Output Feedback	—	17位单圈绝对值 17-bit single-turn absolute value
电机反馈 Motor Feedback	—	UWW霍尔+20000P/R增量编码器 UWW Hall + 20000 P/R Incremental Encoder
通讯接口 Communication Interface	—	EtherCAT/CANopen

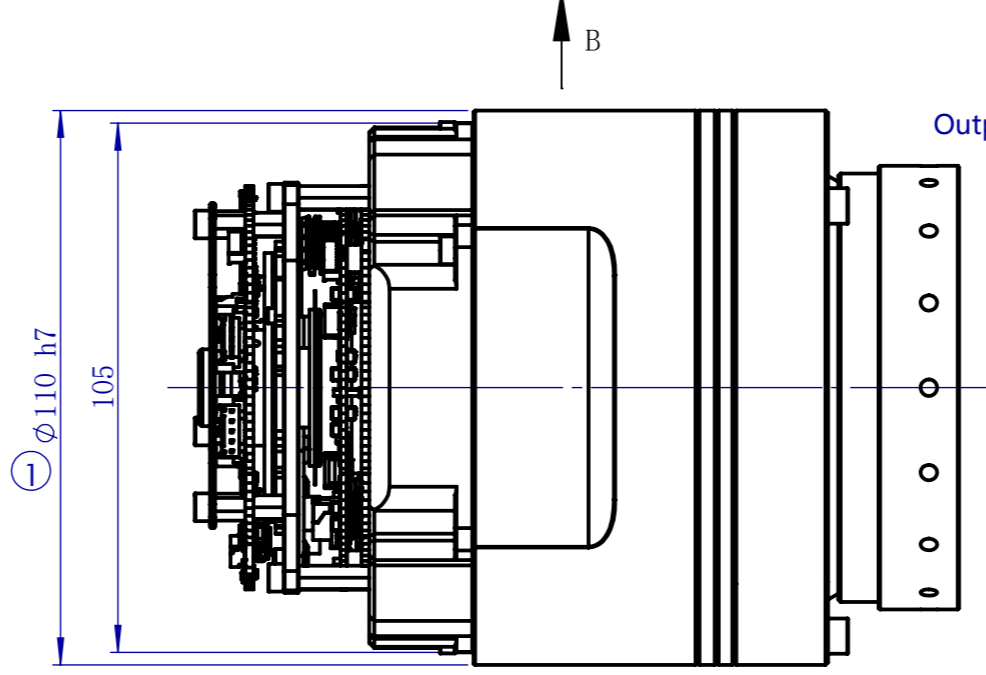

视图 B View B  
比例 1 : 1.5 Scale 1:1.5

16 x M4 - 6H 均布 evenly distributed  
输出法兰径向安装螺钉孔  
Output flange radial mounting screw hole  
剖面 A-A Section A-A  
比例 1 : 1.5 Scale 1:1.5

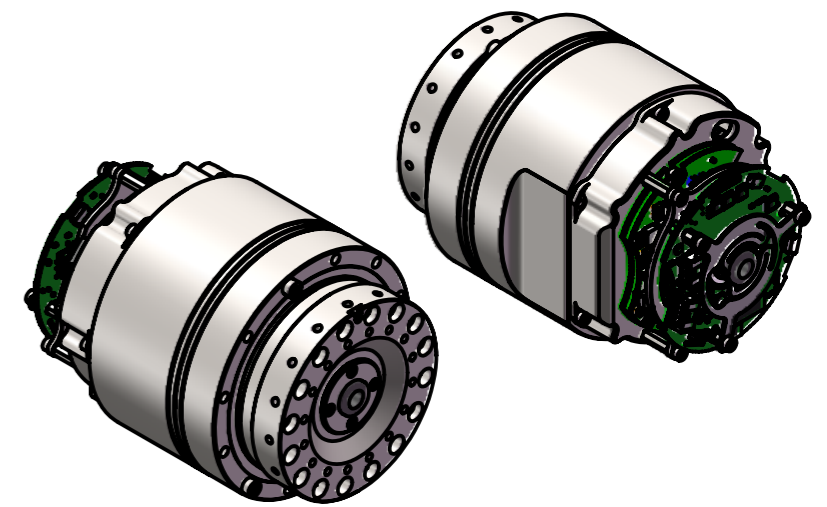

技术说明

1. 紧固螺钉需采用12.9级或以上螺钉并按标准拧紧;
2. 输出法兰可选用轴向或径向两种安装方式;
3. 可选: 输出前端盖可选用RJS II-25前端盖, 方便与RJS II-25模组直接装配;
4. 可选: 嵌入式单维力矩传感器前端盖可选;
5. 可选: 驱动器可与模组分开安装以最大缩短长度, 如有需要请联系我们;
6. 121、161速比可选;
7. 支持OEM客户定制。

Technical Description

1. Fastening screws should use screws of grade 12.9 or higher and be tightened according to the standard.
2. The output flange can be optionally installed axially or radially.
3. Optional: The RJS II-25 front cover can be selected for easy assembly with the RJS II-25 module;
4. Optional: The front cover with an embedded single-axis torque sensor is available.
5. Optional: The drive can be separately installed from the module to minimize length. Please contact us if needed.
6. 121 and 161 gear ratio is optional.
7. Supports OEM customization.



400-856-5198  
sales@techsoft-robots.com  
www.techsoft-robots.com