

机械参数 Mechanical Parameters	单位 Units	数值 Values
减速器速比 Reducer Ratio	—	121
减速器背隙 Reducer Backlash	arcsec	10
转动精度 Rotational Accuracy	arcmin	1
平均负载转矩 Average Load Torque	N·m	557
启停容许转矩 Start/Stop Allowable Torque	N·m	800
静态负载转矩 Static Load Torque	N·m	600
最大瞬时转矩 Maximum Instantaneous Torque	N·m	1458
最大许用弯矩 Maximum Permissible Bending Moment	N·m	600
最大瞬时弯矩 Maximum Momentary Bending Moment	N·m	1200
额定转速 Rated Speed	rpm	16.5
最大转速 Maximum Speed	rpm	20
关节重量 Joint Weight	kg	17
关节直径 Joint Diameter	mm	184
关节长度 Joint Length	mm	209

电气参数 Motor Parameters	单位 Units	数值 Values
极对数 Number of Poles	—	6
额定功率 Rated Power	W	1050
额定电压 Rated Voltage	VDC	48
额定电流 Maximum Power	Arms	33.7
额定转速 Rated Speed	rpm	2000
额定转矩 Rated Torque	N·m	5
转矩常数 Torque constant	N·m/A	0.148
抱闸 Brake	—	24/12VDC电磁摩擦片式 24/12VDC Electromagnetic Friction Plate
输出端反馈 Output feedback	—	17bit单圈绝对值 17bit single-turn absolute value
电机反馈 Motor feedback	—	UVW霍尔+20000P/R增量编码器 UVW Hall + 20000 P/R Incremental Encoder
通讯接口 Communication Interface	—	EtherCAT/CANopen

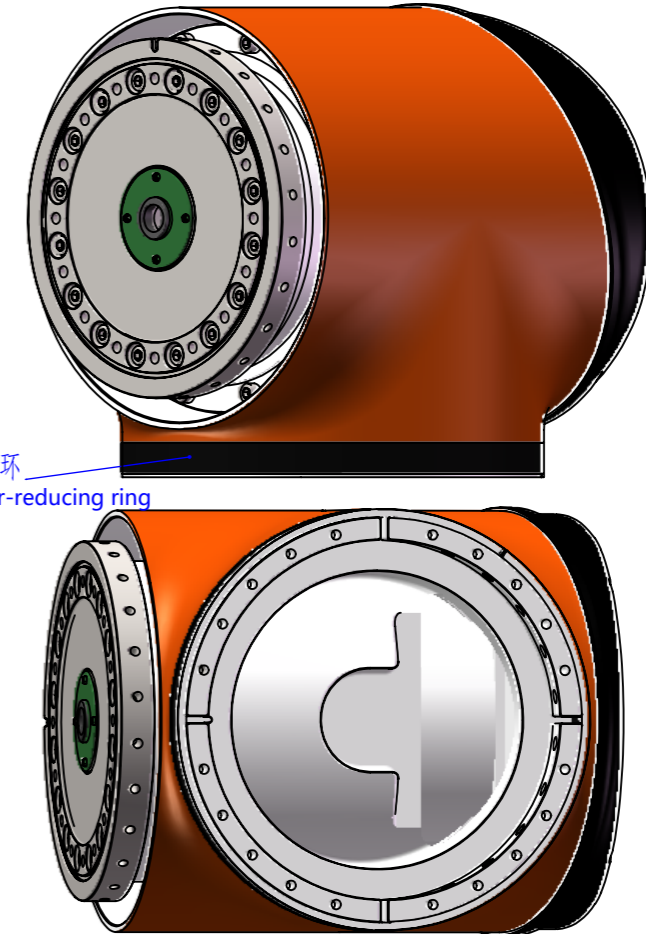
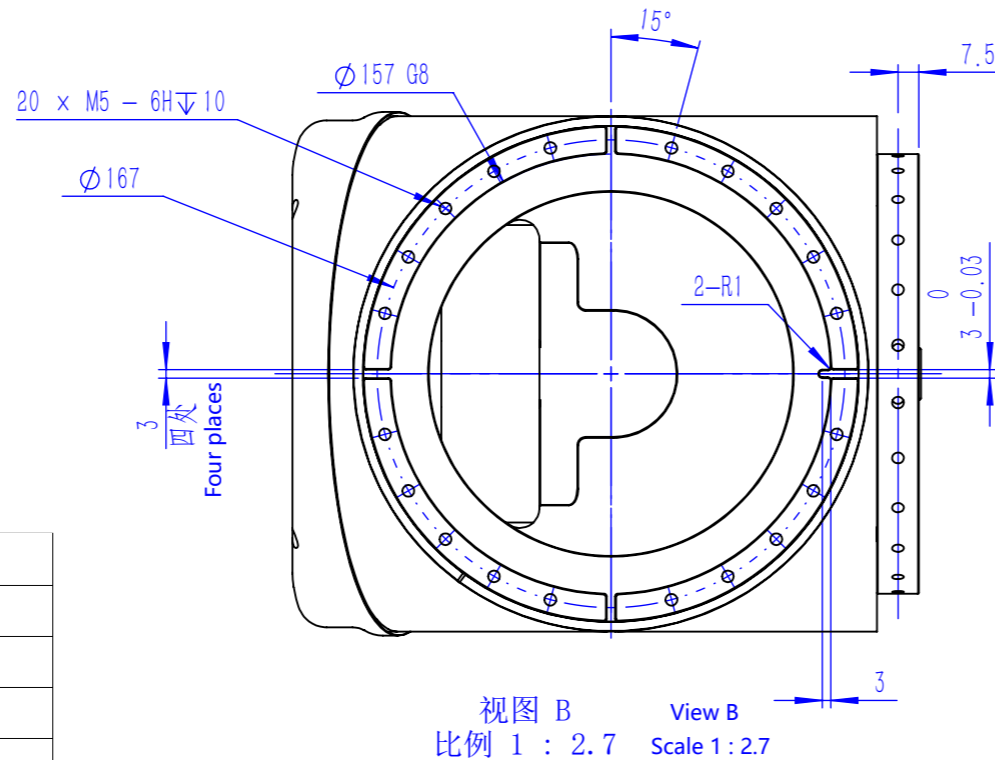

可拆卸弹性环、减磨环  
Removable elastic ring, wear-reducing ring

### 技术说明

1. 紧固螺钉需采用12.9级或以上螺钉并按标准拧紧;
2. 若采用径向连接方式, 关节公母端连接接口设计建议按关节的公母端结构尺寸;
3. 支持OEM客户定制。

### Technical Description

1. Use screws of Class 12.9 or higher and tighten according to standard specifications.
2. If using a radial connection method, the joint male and female end connection interface design is recommended to be based on the structural dimensions of the joint's male and female ends.
3. Reducer ratios of 101 and 161 are optional.
4. Supports OEM customization.



400-856-5198

sales@techsoft-robots.com

www.techsoft-robots.com